

# VACUUM CLEANER AND BLOWER

## Installation, Operation and Maintenance



Figure 1. [91550](#) Vacuum Cleaner

### Description

Compact lightweight blower / vacuum cleaner designed for precise removal and collection of dry dust particles and debris from electrostatic sensitive devices (ESDS). The conductive nozzles drain-off any static build-up to earth.

In order to comply with EN61340-5 recommendations for working in an ESD protected area (EPA), the appliance housing, nozzles, hose, shoulder strap, cable and accessories are fully conductive. The vacuum cleaner can retain dust and fine dry particles as small as 0,3 micron, the vacuum cleaner is fitted with a double-layer paper filter bag and an electro-static charged micro-motor filter.

“Tools intended for use within the EPA [ESD protected area] shall, as far as is practicable, be so constructed that they do not generate or hold an electrostatic charge ....All tools and machinery, for example electrical, mechanical or pneumatic, shall be so constructed that any non-insulating part of the tool or machine which may touch an ESDS [ESD sensitive items] shall be at EPA ground potential.” [EN 61340-5-1 clause 5.2.10 Tools, machinery, dispensers and test equipment]

The appliance can also be converted in seconds into a powerful blower for dust removal in area's otherwise not accessible

- the blower's air-current is cfc-free and contains no oil or water residue.

The appliance is constructed to safety class II: Double insulated design in compliance with CE standards.

- Durable and compact design
- Motor has thermal protection with RFI/EMC filter
- Hose assembly extends to 130cm
- Includes hard crevice and soft rubber nozzle
- 1.2 l filter bag
- Advanced 5 stage filtration system
- 3m long power cord
- Conductive carry strap

### Inspection

Remove the vacuum cleaner from the carton and inspect for shipping damages.

Each unit should include the following:

- 1 Vacuum Cleaner
- 1 1.3m Hose
- 2 Nozzles
- 1 Carrying Strap

### Optional Accessory:

- [91551](#): Replacement Bags, Pack of 10

### Operating instructions

1. Push hose end into suction opening
2. Press the suction nozzle onto the free suction hose-end
3. Place rocker switch in off position
4. Set electronic control to medium power
5. Insert the plug into the electrical supply and start appliance, pressing on-off switch to “on” position.

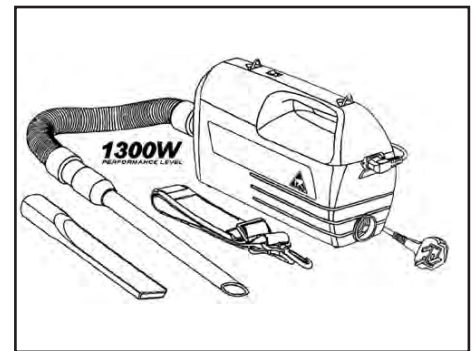

Figure 2. [91550](#) Vacuum Cleaner

If there is substantial loss of vacuum or blow-pressure, take the following steps:

6. Remove appliance from the EPA
7. Check whether nozzle or suction-hose have become blocked
8. Switch off appliance and disconnect plug from electrical supply
9. Lift metal bottom lock and remove housing's front cover
10. Remove and replace the spent paper filter bag
11. Replace electrostatic micro-motor filter.

**Note:** This appliance is equipped with a thermal protection device. To protect the motor from overheating, it will switch off automatically if there is an inadequate air supply. To enable a restart, check filters, bags, nozzle and hose for blockages. Also, reduce the power setting. When the motor has cooled down, the appliance should restart after 15-20 minutes.

### **Safety points**

When cleaning this equipment, ensure it is switched-off and no longer connected to the power supply.

Ensure any object to be cleaned, is itself connected to earth in accordance with EN 61340-5 recommendations.

Always use the on-off rocker switch to turn the appliance on or off.

This appliance is made for indoor use only, it must be stored in a dry place and should not be operated under wet conditions such as wet floors or wet surfaces. Never touch the appliance or the plug with wet hands.

This appliance is not designed, nor suitable, to collect liquids, nor health endangering dust such as asbestos or tropical wood sawdust. Unplug the appliance when it is not in use.

Do not pull the cord to unplug it, do not use the cord to carry or pull the appliance, keep the cord away from hot surfaces. Never use the appliance if the cord or plug are damaged. Never use the appliance if the suction is blocked or with completely restricted vacuum flow or air exit.

Do not operate the vacuum cleaner near flammable or combustible liquids or fumes, do not collect anything that is hot, smoking or burning with the cleaner. Do not pick-up burning cigarettes, hot ashes or matches. Use safety glasses when the application is in blow mode, never blow in corners or in the direction of sharp objects such as staples, paperclips, drawing-pins, needles, pins and glass fragments. Never use the appliance without the filter bag and motor filter in place. Never re-use spent filter bags.

### **Limited Warranty**

Charleswater expressly warrants that for a period of one (1) year from the date of purchase, Charleswater Vacuum Cleaners will be free of defects in material (parts). Within the warranty period, the material will be tested, repaired or replaced at Charleswater's option, free of charge. Call Customer Service at 00 44 (0) 1892-665313 for a Return Material Authorisation (RMA) and for proper shipping instructions and address. You should include a copy of your original packing slip, invoice, or other proof of purchase date. Any unit under warranty should be shipped prepaid to the Charleswater factory. Warranty replacements will take approximately two weeks.

### **Warranty Exclusions**

THE FOREGOING EXPRESS WARRANTY IS MADE IN LIEU OF ALL OTHER PRODUCT WARRANTIES, EXPRESSED AND IMPLIED, INCLUDING MERCHANTABILITY AND FITNESS FOR A PARTICULAR PURPOSE WHICH ARE SPECIFICALLY DISCLAIMED. The express warranty will not apply to defects or damage due to accidents, neglect, misuse, alterations, operator error, or failure to properly maintain, clean or repair products.

### **Limit of Liability**

In no event will Charleswater or any seller be responsible or liable for any injury, loss or damage, direct or consequential, arising out of the use of or the inability to use the product. Before using, users shall determine the suitability of the product for their intended use, and users assume all risk and liability whatsoever in connection therewith.